

Submittal

RSH1548S1A - Split System Air Conditioner

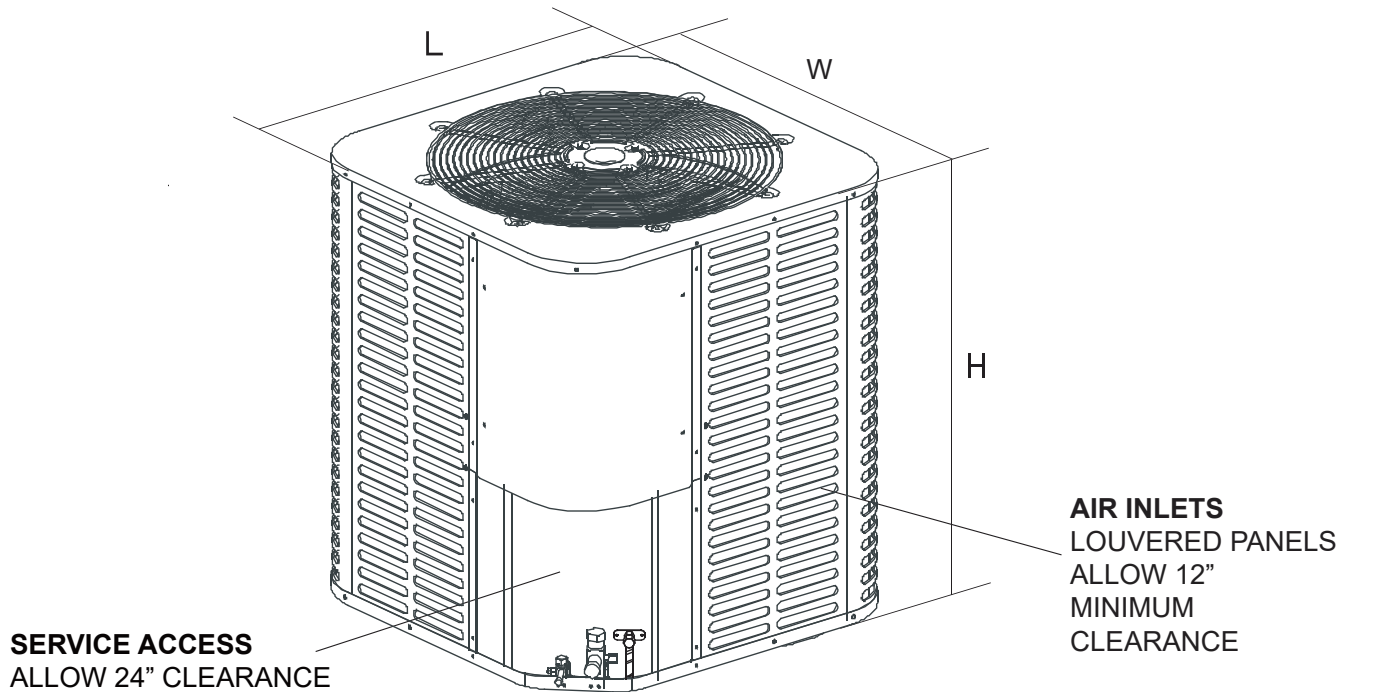

NOTE: GRILL APPEARANCE
MAY VARY.

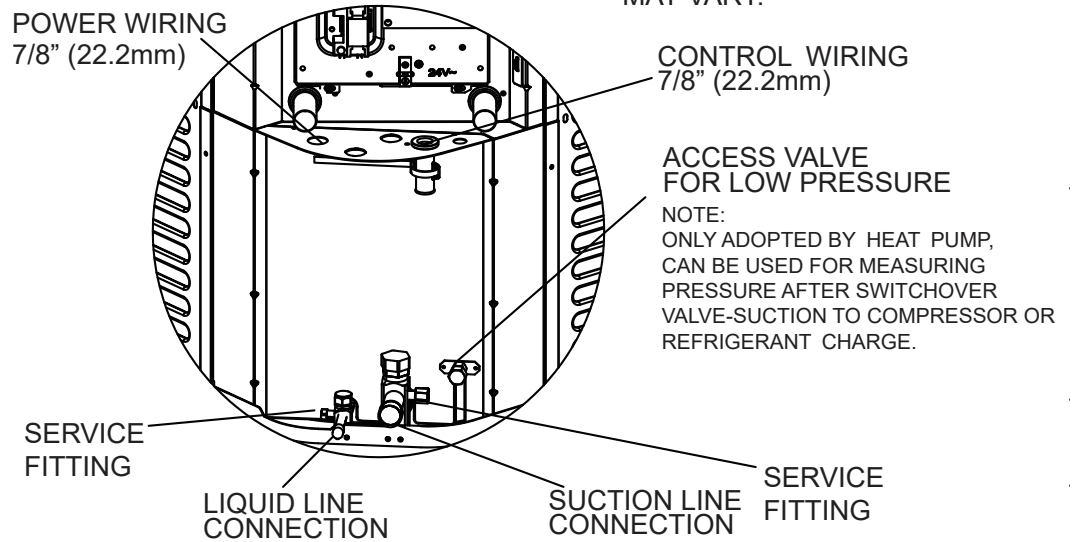

Note: All dimensions are in mm/inches.

RSH1548S1A	H	W	L	Liquid Valve Size	Gas Valve Size
	843 (33/3/16)	740 (29-1/8)	740 (29-1/8)	3/8	7/8

PRODUCT SPECIFICATIONS:

MODEL	RSH1548S1A
Power Conns. — V/Ph/Hz	208-230/1/60
Min. Brch. Cir. Ampacity	29.6
Br. Cir. Prot. RTG. — Max. (Amps)	50
Compressor	Scroll
No. Used - No. Speeds	1 - 1
Volts/Ph/Hz	208-230/1/60
R.L. Amps - L.R. Amps	8.0-94
Factory Installed	
Start Components	No
Insulation/Sound Blanket	No
Compressor Heat	No
Outdoor Fan/Motor	Propeller/ECM
Dia. (In.) - No. Used	23-5/8-1
Type Drive - No. Speeds	External - 10
CFM @ 0.0 In. W.G.	3850
No. Motors — H.P.	1 - 1/3
Motor Speeds R.P.M.	1050
Volts/Ph/Hz	208-230/1/60
F.L. Amps	2.2
Outdoor Coil — Type	Plate Fin
Rows - F.P.I.	2 - 21
Face Area (Sq. Ft.)	18.4
Tube Size (In.)	3/16
Refrigerant	R-410A
lbs. — R-410 (O.D. Unit)	8 lbs. - 7 Oz
Factory Supplied	Yes
Line Size - In. O.D. Gas	1-1/8
Line Size - In. O.D. Liq.	3/8
Charging Specification Superheat	9° F
DIMENSIONS	H x W x D
Crated (In.)	34-1/2x 30-1/5 x 30-1/5
Shipping (Lbs.) / Net (Lbs.)	227/91

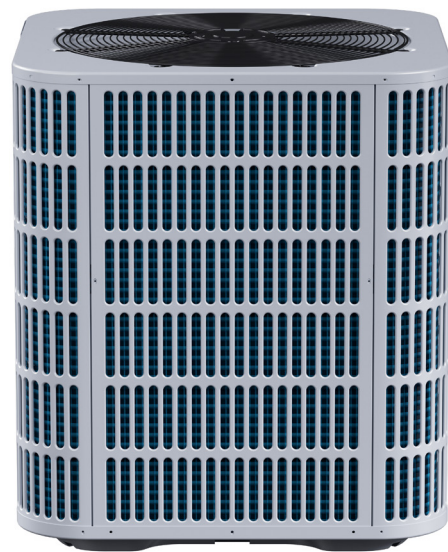

Submittal

RSH1548S1A

STANDARD FEATURES:

- R410A chlorine-free refrigerant
- Energy-efficient compressor
- Internal protection against high temperature motor overload conditions
- High quality copper tube and aluminum fin condenser
- Service valves with sweat connections and easy-access gauge ports
- Factory-installed high pressure switch and low pressure switch
- AHRI certified and ETL listed
- Filter drier included

CABINET FEATURES:

- Unique top design for sound control
- Compact design, easy installation, and transportation
- Powder-coated galvanized steel cabinet
- Wire fan grille
- Steel louver coil guard